



The Impact of PBS

Brian Chuang
Mechanical Engineer (PBS)

Agenda

1. PBS Overview
2. PBS Safety and Infrastructure Standards
3. PBS Statistics
4. Common PBS Combination Examples
5. Innovative PBS Combination Examples
6. Australian Standards – Dangerous Goods

PBS Overview

- 🚛 On-road performance rather than prescriptive regulation
- 🚛 16 safety and 4 infrastructure standards, including stability and swept path, pavement and bridge impacts
- 🚛 Matching the right vehicles to the right roads, vehicle performance determines access level (PBS Level 1-4)
- 🚛 PBS vehicles are designed under a more rigorous system than prescriptive vehicles
- 🚛 **2007** Introduced by NTC/Austrroads >> **2013** managed by NHVR >> **2014** incorporated into Heavy Vehicle National Law (HVNL)

PBS Safety and Infrastructure Standards

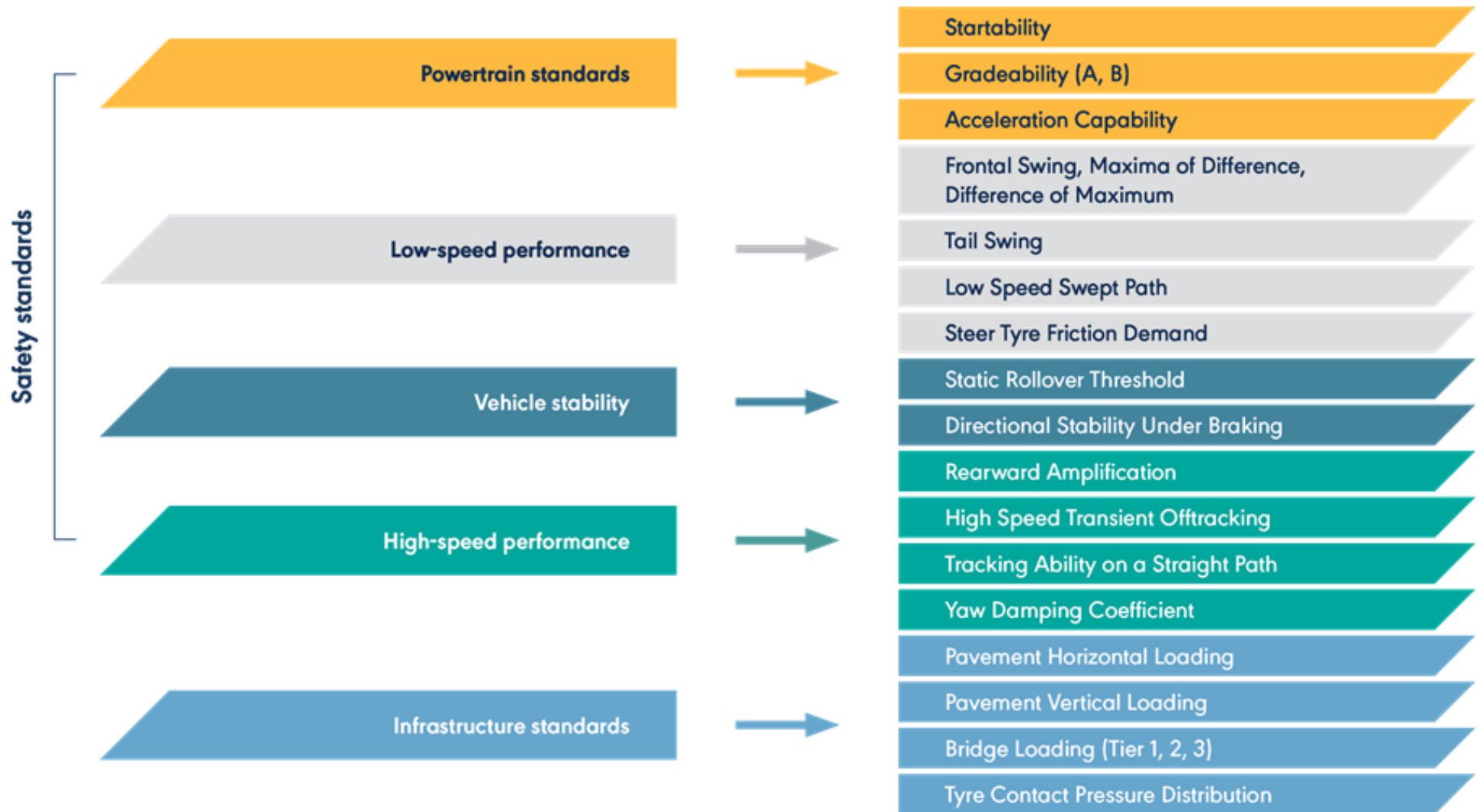

PBS Statistics

PBS fleet yearly compounded growth

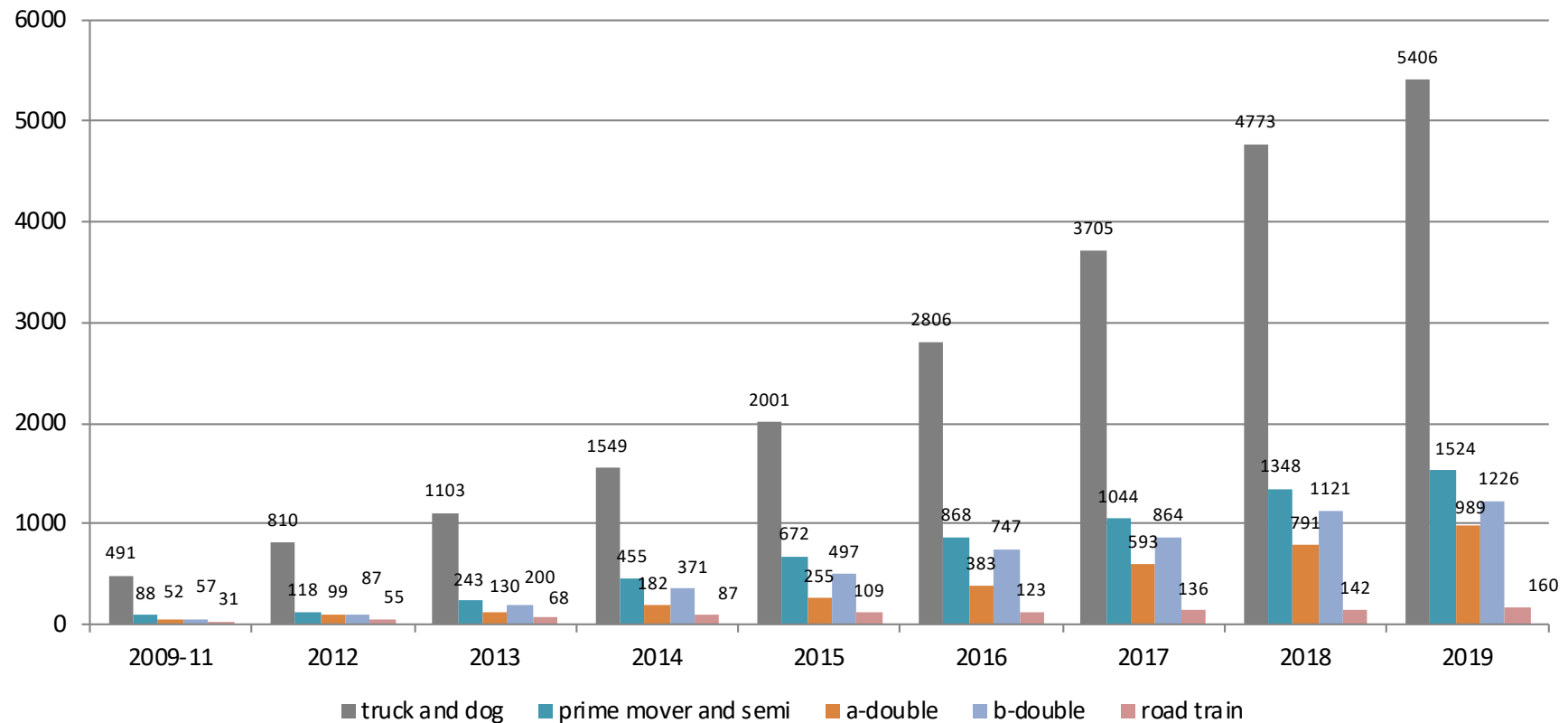

PBS Statistics

Number of PBS Tanker Combinations

410

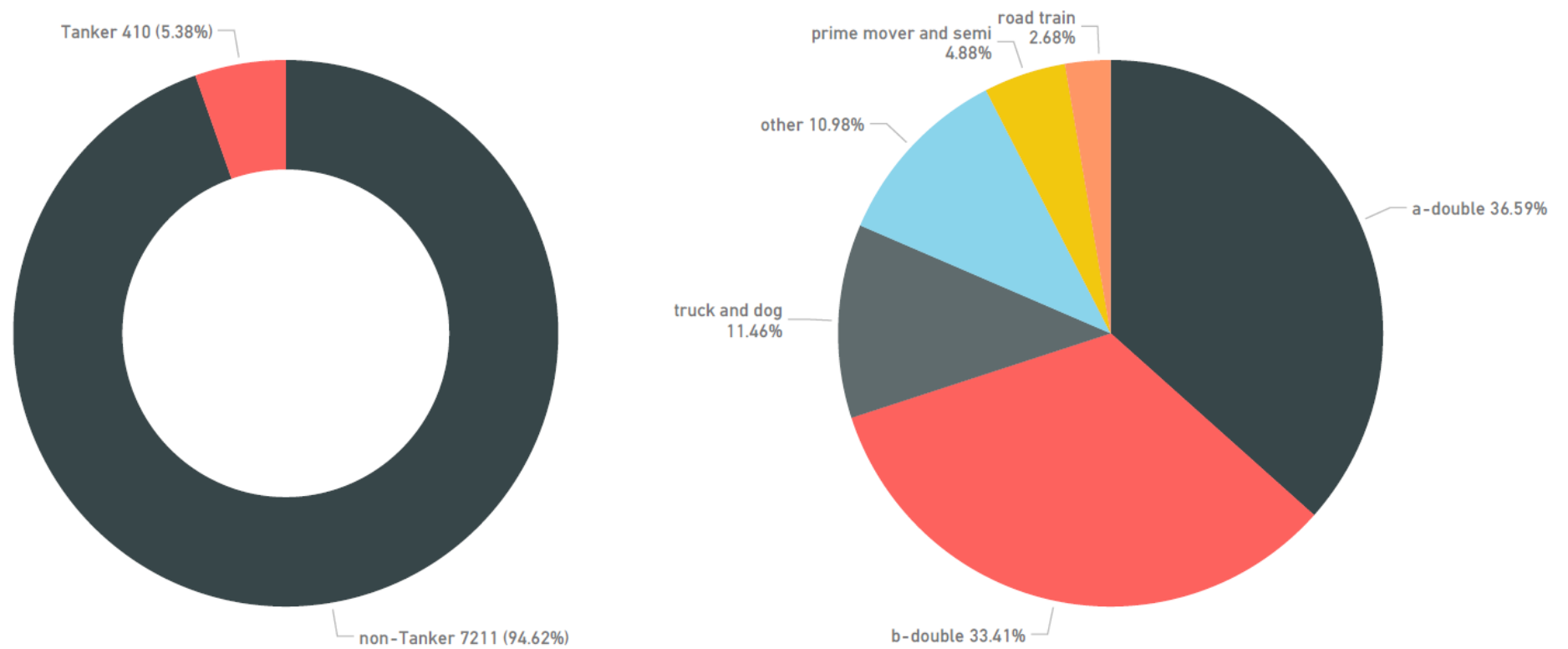

PBS Statistics

Design Applications

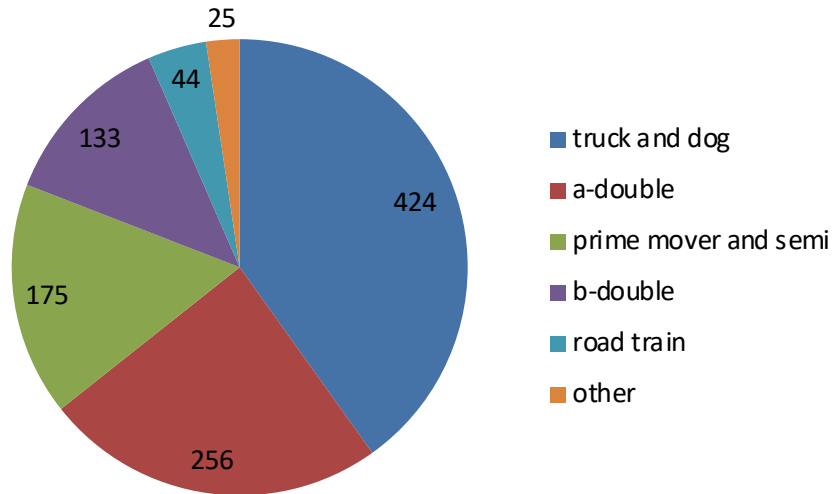

Design Application Load Type

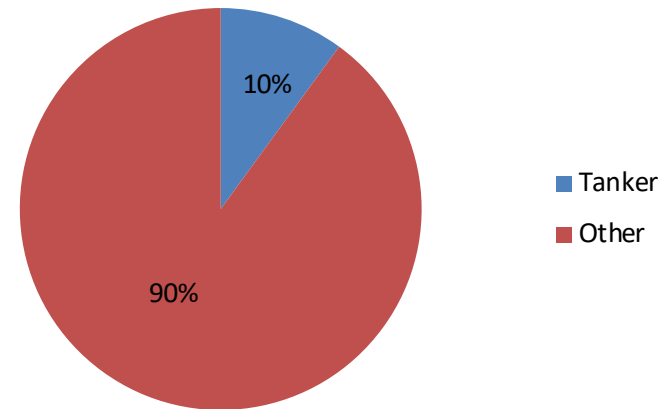

Design Application Types of Tankers

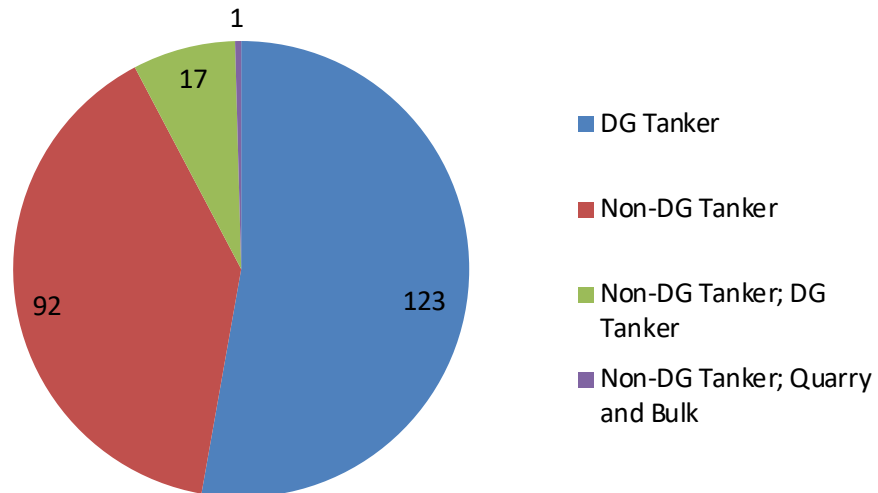

Common PBS Combination Examples

20m Prime Mover Quad Semi

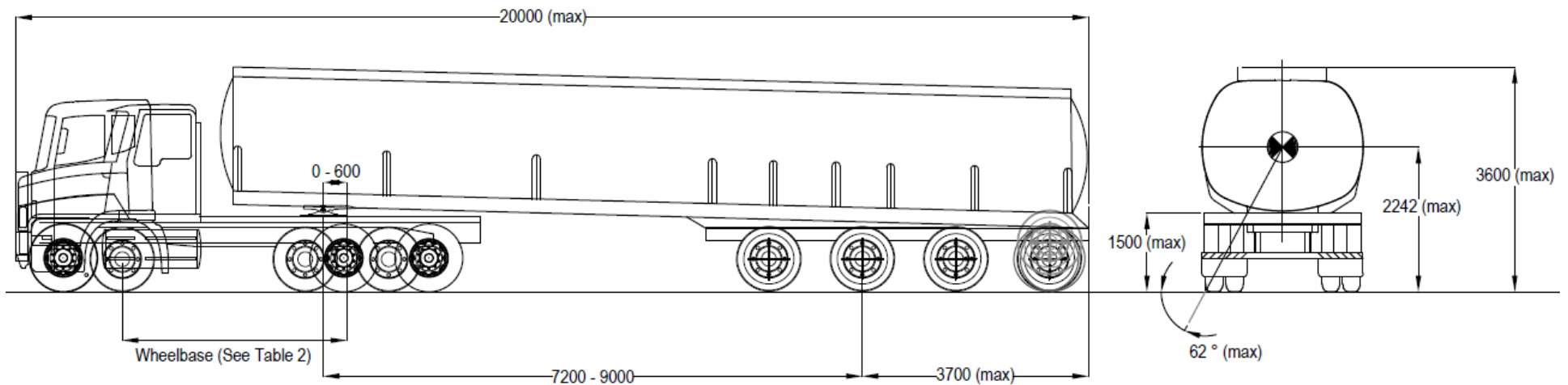

Total Combination Mass up to 50.5t PBS at Level 1

Common PBS Combination Examples

20m 3-axle Truck 4-axle Dog

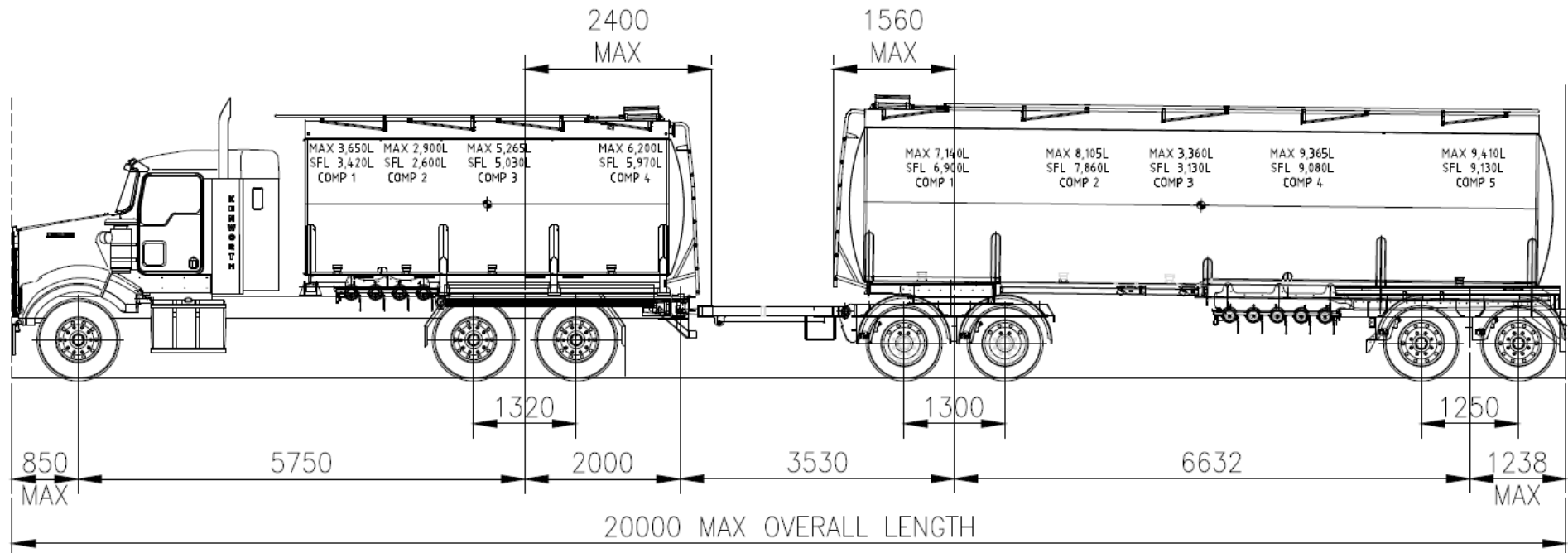

Total Combination Mass up to 50.5t at PBS Level 1

Total Combination Mass up to 57.5t at PBS Level 2

Common PBS Combination Examples

26m A-double (2-2-2)

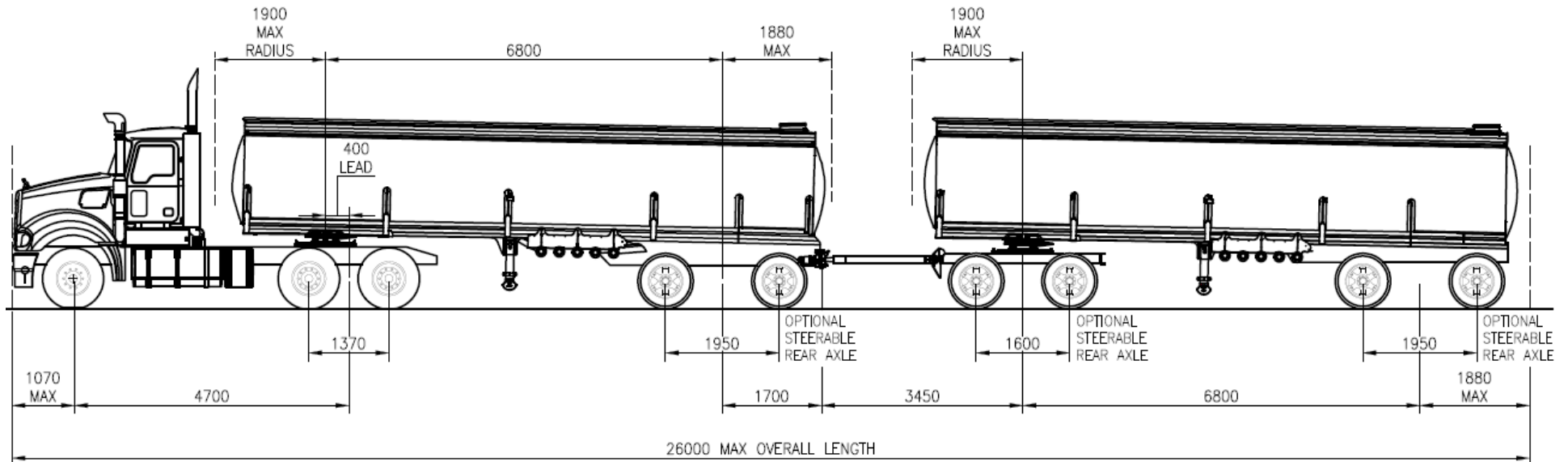

Total Combination Mass up to 74.5t at PBS Level 2

Common PBS Combination Examples

40m AB-triple (3-3-3-3)

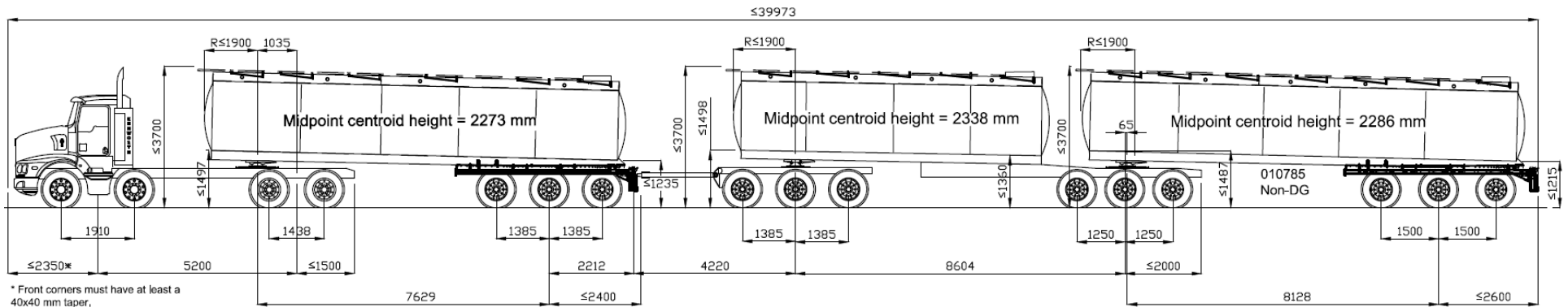

Total Combination Mass up to 118t at PBS Level 3

Innovative PBS Combination Examples

A-double (4-3-4) "Super Pocket"

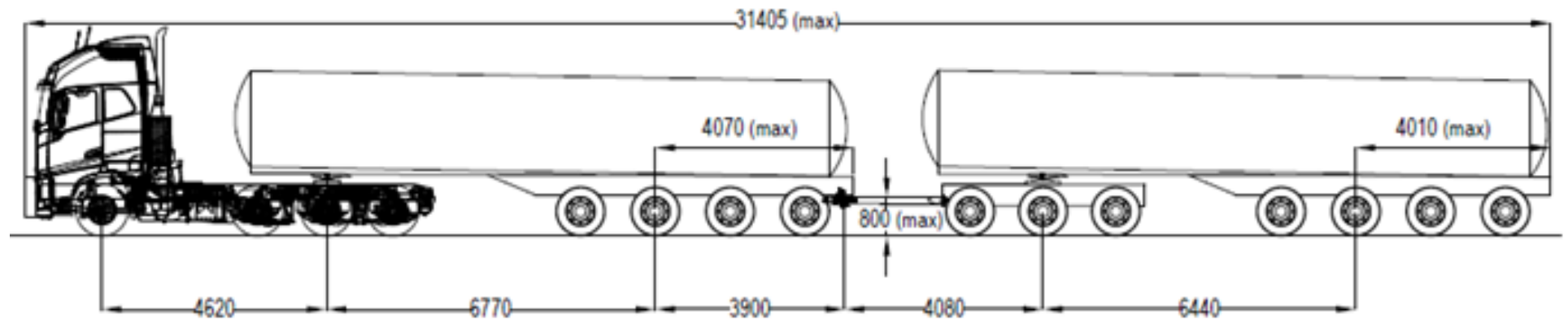

Total Combination Mass up to 105.5t at PBS Level 3

Innovative PBS Combination Examples

3-axle Prime Mover and Semitrailer with two axle groups (2-1)

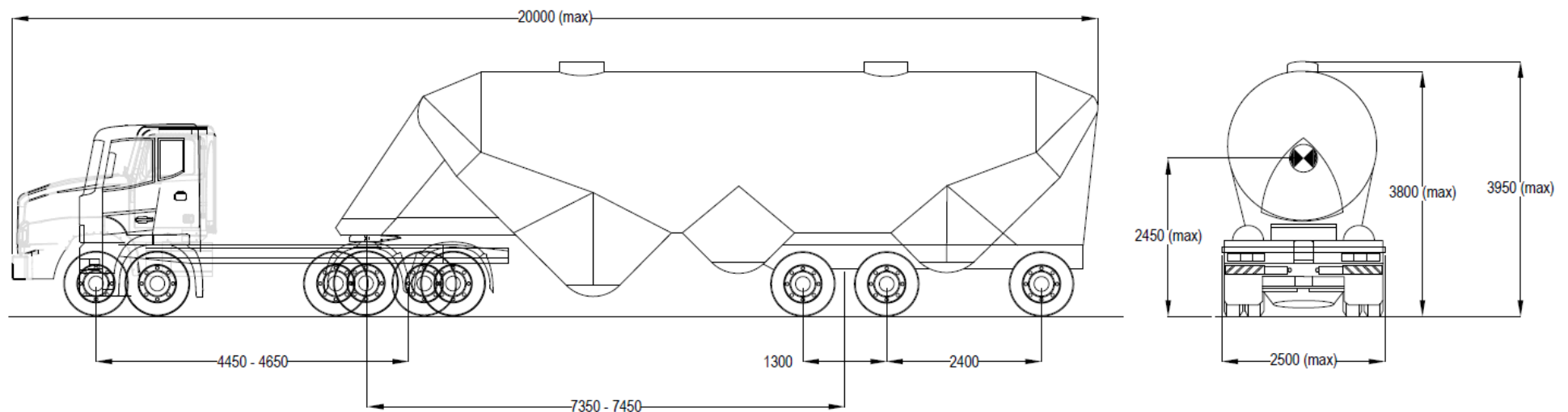

Total Combination Mass up to 49t at PBS Level 1

Australian Standards – Dangerous Goods

- Australian Standard AS2809 (road tank vehicles for dangerous goods) under review
- Draft of AS2809.1 (general requirements) allows for stability triangle or PBS SRT assessment
- AS2809.1 meeting to consider public comments (September 2019)
- Once published and legislated, both stability methods are allowed
- The DG design approval will state the stability requirements
- PBS design applications are still required to do SRT assessment

Thank You

