

Prevention is Better than cure.

A Responder's point of view.

Anthony Pospisil

Manager Quality, Risk and Compliance

ISS First Response

BULK TANKER EMERGENCY RESPONSE

sharing lessons and improving outcomes

20th October
Melbourne Park Function Centre

Hosts



National Bulk Tanker Association

Prevention is better than cure.

Emergency Response Preparedness.

A simple case explaining the
benefits of having a
Transport Emergency Response Plan

(or, preventing a bigger mess than the one that
caused all this in the first place)

I always wanted to be a truck driver. So I bought a truck. I'm in business!



This is my new truck

It is a beautiful truck, even from behind!

It carries diesel fuel for my employer.

I like being a truck driver for another company.

“six days on the road now I'm gonna make it home tonight”

Life is good!

**BULK TANKER
EMERGENCY
RESPONSE**
sharing lessons and
improving outcomes

20th October
Melbourne Park Function Centre

The stakeholders and interested parties involved in my new business are;



Me (the owner and driver)

my wife ('the' Boss)

my employer (the other Boss)

my Insurance Company (the Big Boss)

**BULK TANKER
EMERGENCY
RESPONSE**
sharing lessons and
improving outcomes

20th October
Melbourne Park Function Centre

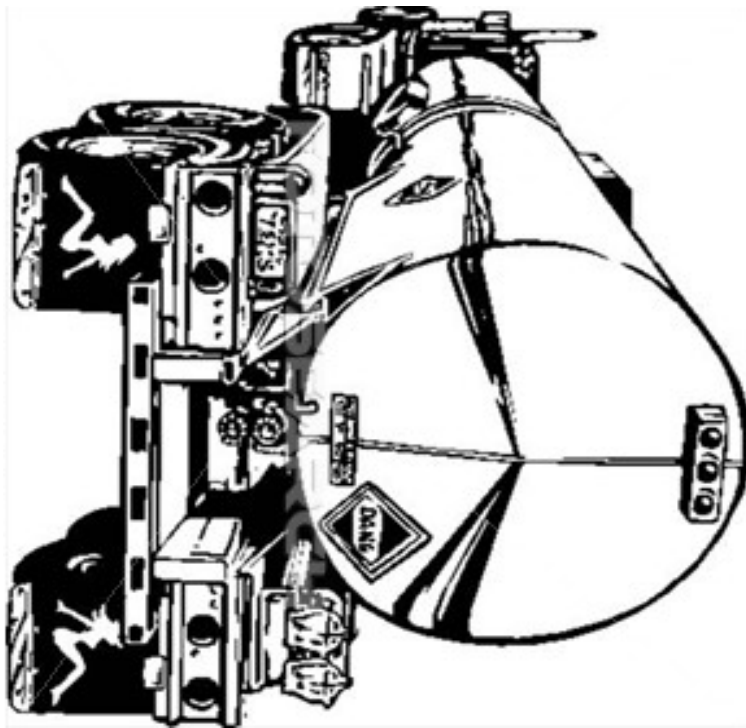

oops!

**BULK TANKER
EMERGENCY
RESPONSE**
sharing lessons and
improving outcomes

20th October
Melbourne Park Function Centre

The stakeholders and interested parties involved in my business NOW, are;

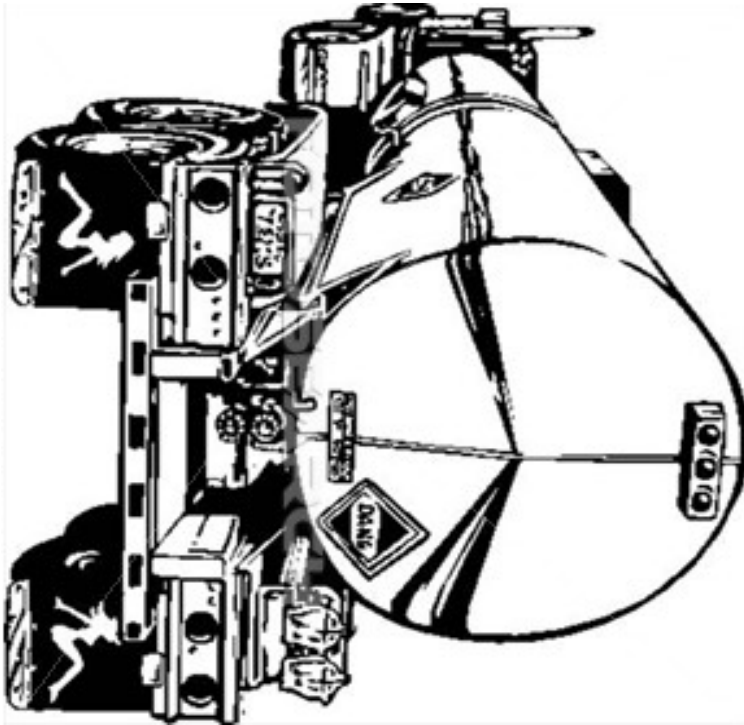

Me, and the
Fire Brigade
Police
Ambulance
my employer
Depot manager and staff
Opposition company - for mutual aid (tanker)
Traffic controllers
Crane Operator
Towing Company
Road Authority - State and/or local
Workcover Authority
Vehicle / tank repairer
Customer needs / business continuity
Insurance Company, and
my wife.

**BULK TANKER
EMERGENCY
RESPONSE**
sharing lessons and
improving outcomes

20th October
Melbourne Park Function Centre

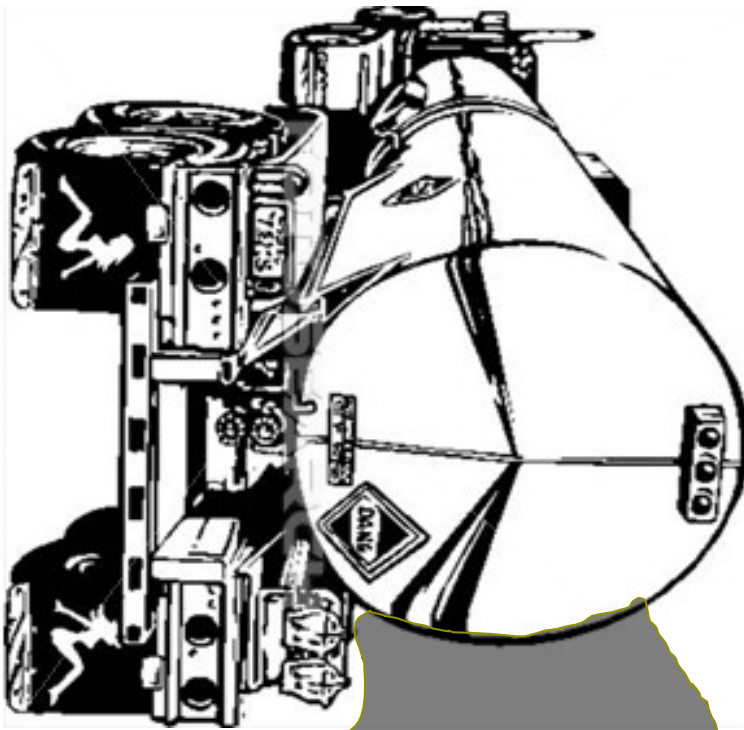

I seem to have sprung a leak.

**BULK TANKER
EMERGENCY
RESPONSE**
sharing lessons and
improving outcomes

20th October
Melbourne Park Function Centre

The stakeholders and interested parties involved in my business NOW, are;

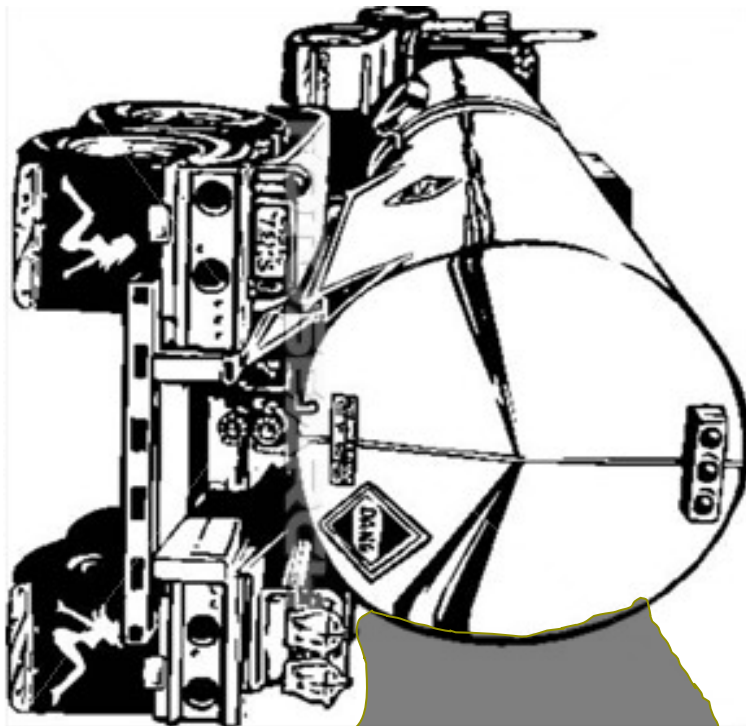

Me, and the

Fire Brigade, Police, Ambulance
employer

Depot manager and staff

Hole cutter / cold tapper – (local engineer, fly-in expertise?)

Opposition company - for mutual aid (tanker)

Traffic controllers

Crane Operator

Towing Company

Road Authority – State and/or local

Workcover Authority

Vehicle / Tank repairer

Customer needs / business continuity

Insurance Company

and also;

Local Council – sand supplies, absorbents

Underground Utilities - plans for Gas, Electricity, Water, Sewer

Environment Protection Authority / Local Environmental Officer

Excavator/s – excavation of contaminant

Tippers and dogs – transport of waste soils

Environmental Expertise – remediation/validation/EPA Waste

EPA Prescribed waste facilities / landfills (solids and liquids)

Groundwater monitoring - permits and wells

Assessors, and

my wife.

**BULK TANKER
EMERGENCY
RESPONSE**
sharing lessons and
improving outcomes

20th October
Melbourne Park Function Centre

The stakeholders and interested parties involved in my business NOW, are;

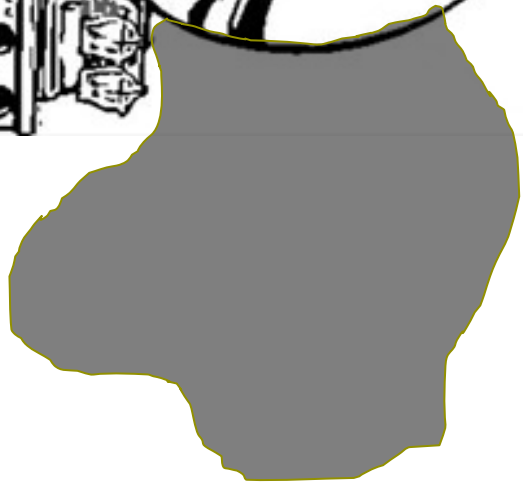
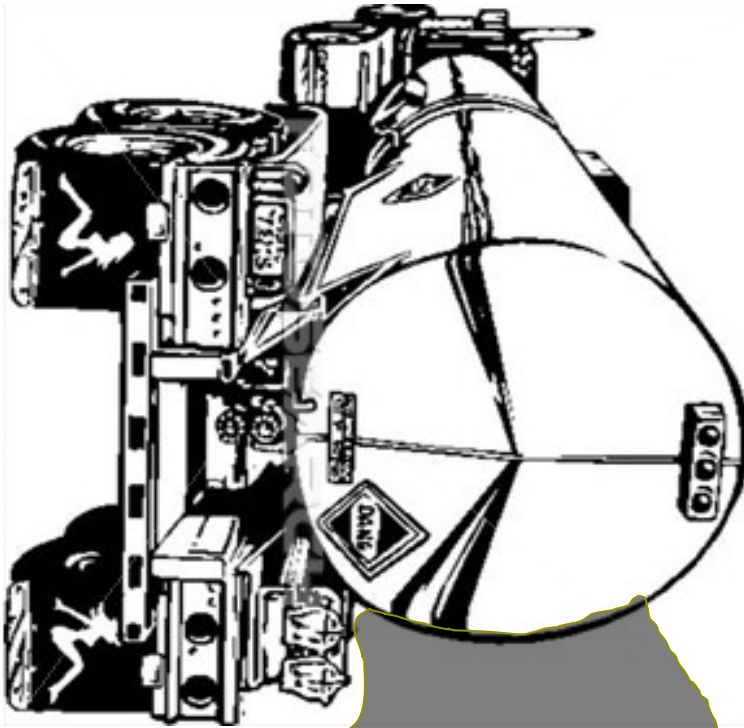

Where is this fuel going ?

**BULK TANKER
EMERGENCY
RESPONSE**
sharing lessons and
improving outcomes

20th October
Melbourne Park Function Centre

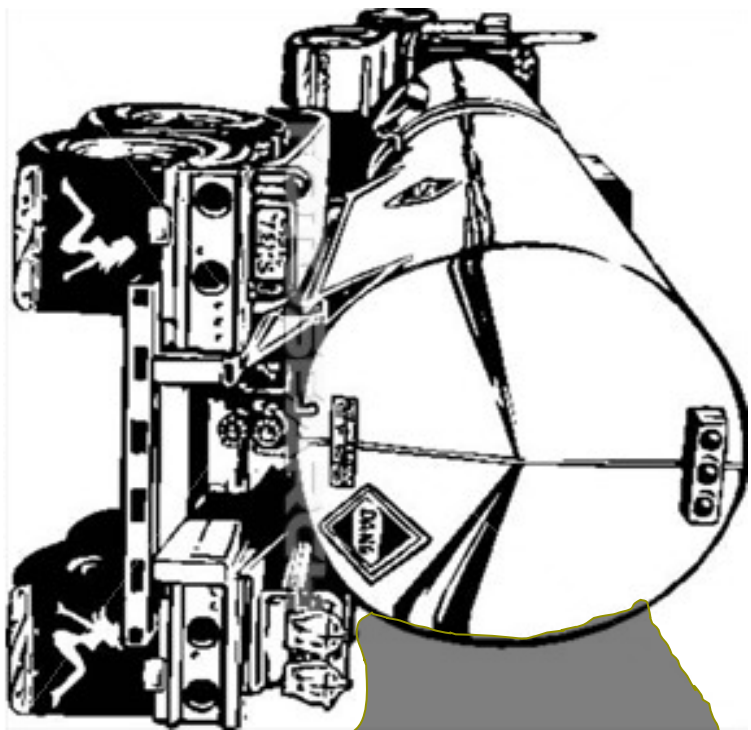

‘That is the second biggest drain I have ever seen’.

(Maxwell Smart)

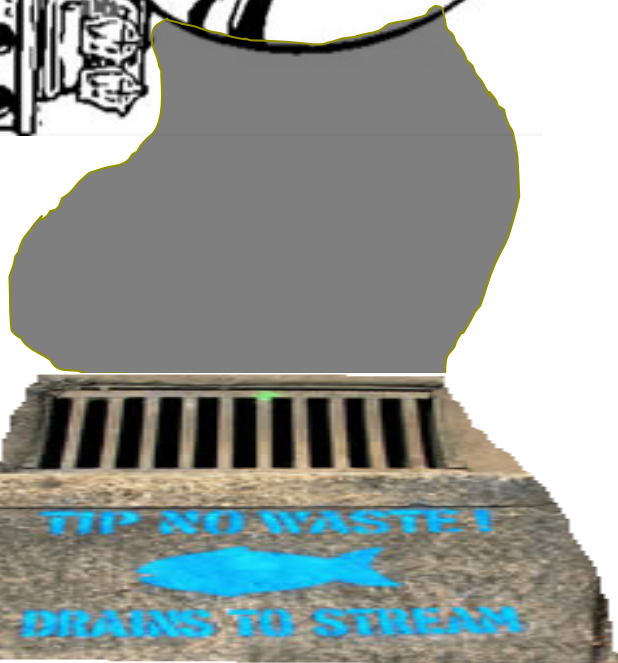

**BULK TANKER
EMERGENCY
RESPONSE**
sharing lessons and
improving outcomes

20th October
Melbourne Park Function Centre

The stakeholders and interested parties involved in my business NOW, are;

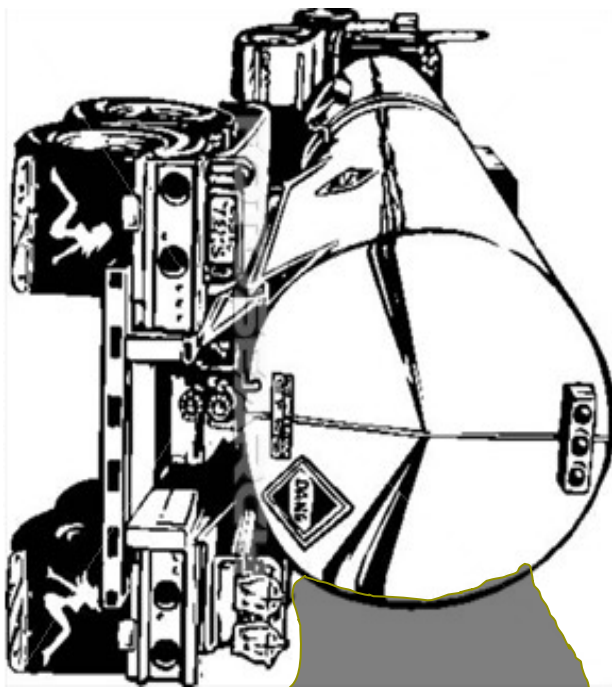

Me, and the

Fire Brigade, Police, Ambulance,

employer, Depot manager and staff

Opposition company - for mutual aid (tanker)

Traffic controllers

Crane Operator and his crew Towing Company

Road Authority - State and/or Local

Workcover Authority

Vehicle / Tank Repairer

Customer needs / business continuity

Insurance Company

Local Council – sand supplies, absorbents

Underground Utilities - plans for Gas, Electricity, Water, Sewer

Environment Protection Authority / Local Environmental Officer

Excavator driver – excavation of contaminant

Tippers and dogs – transport of waste soils

Environmental Expertise – remediation / validation / EPA Waste

EPA Prescribed waste facilities / landfills (solids and liquids)

Groundwater monitoring - permits for drilling and well installation

and also,

Extra spill control equipment – depot or local supplier.

Waste Management Company - Vacuum truck and crew

The DEWHA - EPBC Act 1999

Insurance Assessors and

Counselling - employment, trauma and marriage.

**BULK TANKER
EMERGENCY
RESPONSE**
sharing lessons and
improving outcomes

20th October
Melbourne Park Function Centre

The stakeholders and interested parties involved in my business NOW, are;

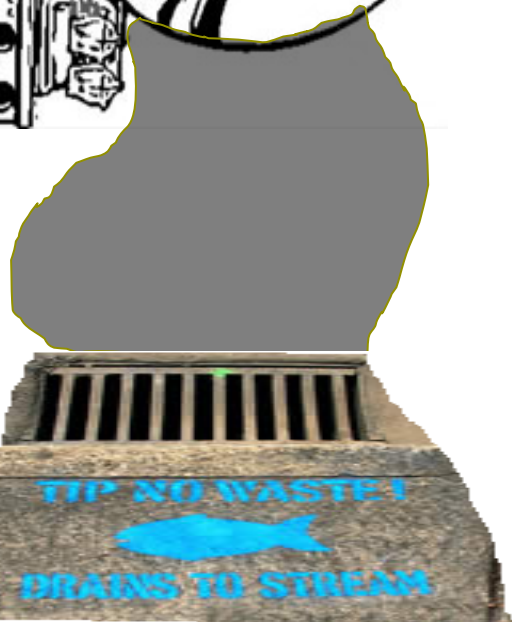
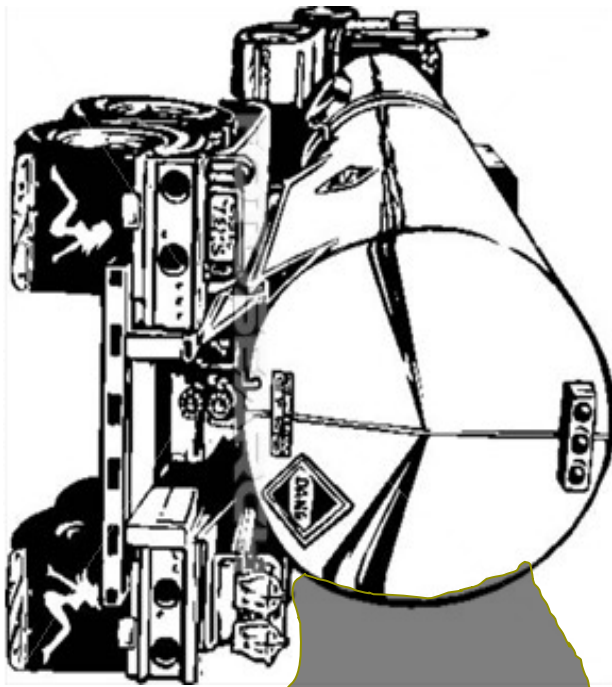

What else could go wrong?

**BULK TANKER
EMERGENCY
RESPONSE**
sharing lessons and
improving outcomes

20th October
Melbourne Park Function Centre

'I found it! It's over here!'



Look at this beautiful lake!

And what lovely swans!

Can you hear the frogs?

The stakeholders and interested parties involved in my business NOW, are;

every man and his dog
(and my wife)

A TERP won't stop your vehicle rolling over - but it will prevent the organic matter from hitting the rotating machine, afterwards.

A TERP can help you to:

- think about emergency scenarios and plan for them
- determine who does what – roles, responsibilities, duties
- identify who has what resources and where they are - mobilise
- work together in a time of stress and crisis
- facilitate a rapid & effective response and recovery, minimising harm
- provide assistance to emergency and security services
- communicate with internal and external personnel
- cover your backside - from those possibly coming later
– ('what did you do?.....and where's your TERP?')

Thank you.